

LCF316

316 Litre Chest Freezer

Serving Australia since 1956

Features

- 316L Storage Capacity
- Durable white cabinet
- Water disposal device
- Storage basket
- Electronic temperature control
- Power indicator function
- Compressor switch off function
- Wheels on base

Technical Features:

- Energy rating: 2.5 star
- 42dB(A)
- R600a refrigerant

Power:

- 220 – 240V ~ 50Hz
- 1.45A amp
- 423kW per year

2 Year Warranty

Product Dimensions:

845mm H x 1120mm W x 700mm D

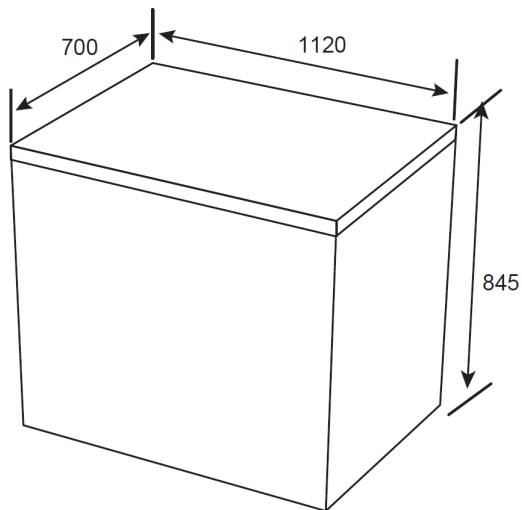

Lemair